

SALES DRAWING

SALES DRAWING

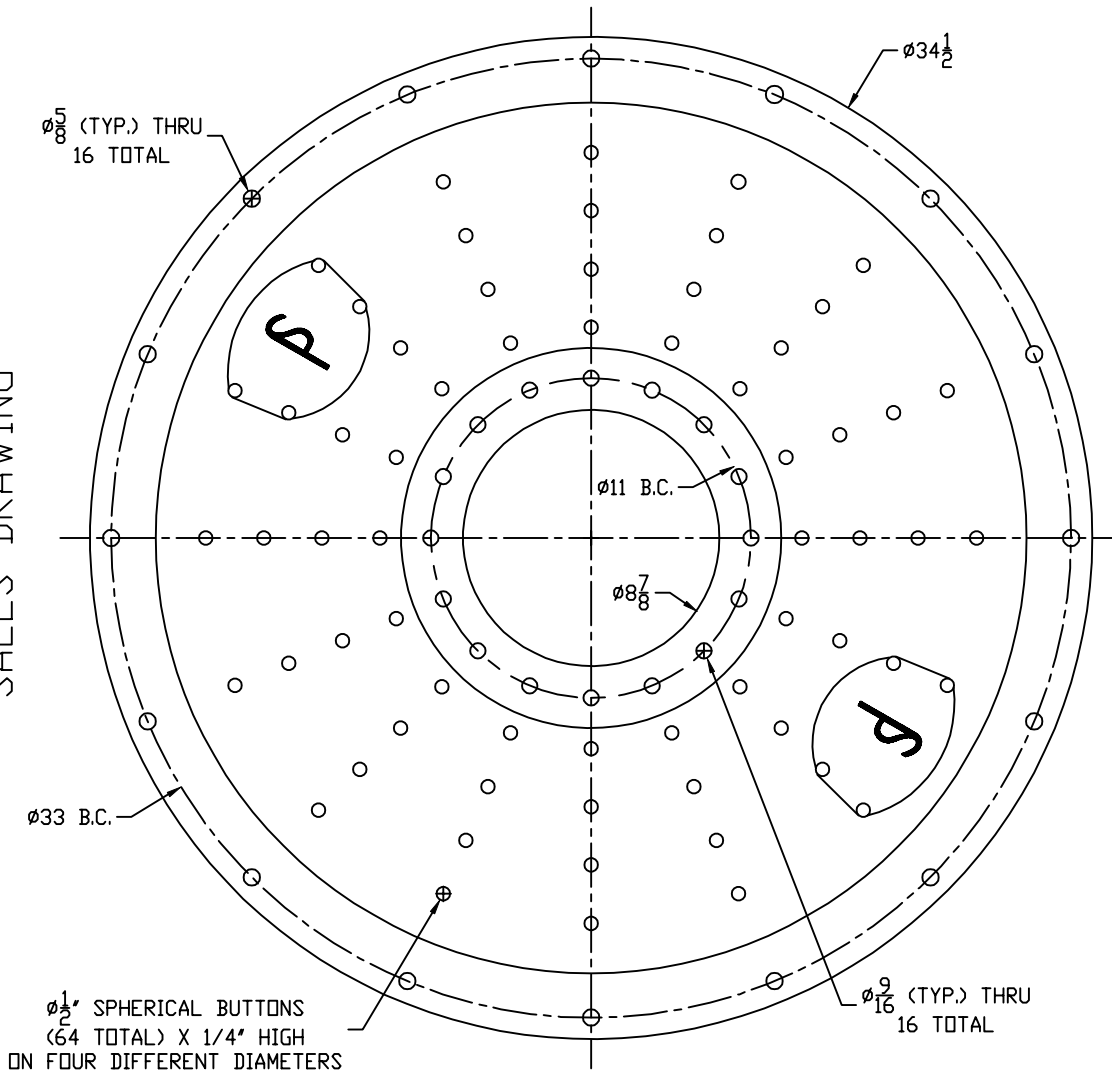

- NOTES:
1. MATERIAL SPEC. FOR FABRIC: FDA 3 PLY SOLID WOVEN COTTON, 5/32" THICK.
 2. MATERIAL SPEC. FOR GASKET: TAN FDA SBR.
 3. GASKET THICKNESS IS .125" ON EACH SIDE. OVERALL THICKNESS OF PART INCLUDING FABRIC AND GASKET IS .41 ± .03.

1/2" SPHERICAL BUTTONS
(64 TOTAL) X 1/4" HIGH
ON FOUR DIFFERENT DIAMETERS

UNLESS OTHERWISE SPECIFIED DIMENSIONAL TOLERANCES:		REV. BY		DATE	DESCRIPTION
FRACTIONAL	±1/16	SALCO PRODUCTS, INC.			2D
X.XX	±0.03	DRAWN BY: SAB	CHKD BY: KRSJ	SCALE: 1:2	APPROVAL DATE:
X.XXX	±0.015	MATERIAL: SEE NOTES 3 & 4			
ANGULAR	±1°	PART NAME: PD1 AERATOR PAD ASSEMBLY			
THIS DRAWING IS THE PROPERTY OF SALCO PRODUCTS, INC. IT IS TO BE USED FOR THE PROJECT AND DATE SHOWN HEREON. IT IS TO BE KEPT IN THE OFFICE OF THE PROJECT ENGINEER AND NOT REPRODUCED OR COPIED WITHOUT HIS WRITTEN PERMISSION.					
THIRD ANGLE PROJECTION		PROJECT #	981115	DATE	SAB 3-22-99
		DRAWING #	D13284	PART #	PD1AP3C23